

# TV Spectrum Repack Process Update & ATSC 3.0 Considerations.

Joe Seccia

IEEE BTS 2017

Arlington, VA



# How Many Stations Directly Impacted?

Spectrum Recovered MHz	Highest Remaining TV Channel	Full Power Stations	Class A Stations	Total Stations Directly Impacted*
84	36	593	144	737

**Directly impacted** stations are those currently assigned to spectrum that is to be cleared for wireless services

\*Some participated in the auction, thus reducing the number of directly impacted stations



# TV Repack Report Card



Action as a Result of the Spectrum Auction	Number
Stations Eliminated (Not Including Channel Sharing)*	<b>145</b>
Stations Moving From UHF to VHF*	<b>30</b> 17 LB 13 HB
Stations Relocated Within the UHF Band (US Only)	<b>917</b>
Distributed Transmission Stations Relocated	<b>19</b>
Stations Relocated Within the VHF Bands (US Only)	<b>70</b>
Canadian Stations Forced to Relocate	<b>62</b>
Total Repacked (not including VHF moves)	<b>1068</b>



# Stations Not Changing Channels Impacted

- **IF stations....**
  - Share a Tower
  - Have stacked tower top antennas
  - Operate on a shared antenna and transmission line**...with a station that is forced to change channel**
- **FM stations on a shared tower with TV**
- **Additional issues**
  - Who will pay the cost for accommodating these stations?
  - Potential increased interference from neighboring stations (0.5% of population per other station)



# New UHF Band Plan

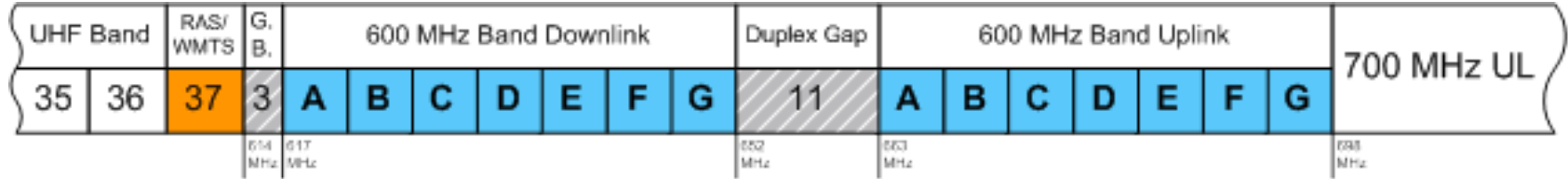

- Wireless spectrum channelized into 5 MHz pairs
- TV service remains 6 MHz channels
- Duplex gap between wireless uplink and downlink
- Guard band spectrum between services



# Ch. 14 scenario

- 20 *Full-power* Ch. 14 assignments before repack
  - 8 get repacked off Ch. 14
  - 12 remain on Ch. 14
- 30 *Full-power* stations repacked to Ch. 14
  - 42 *Full-power* Ch. 14 assignments

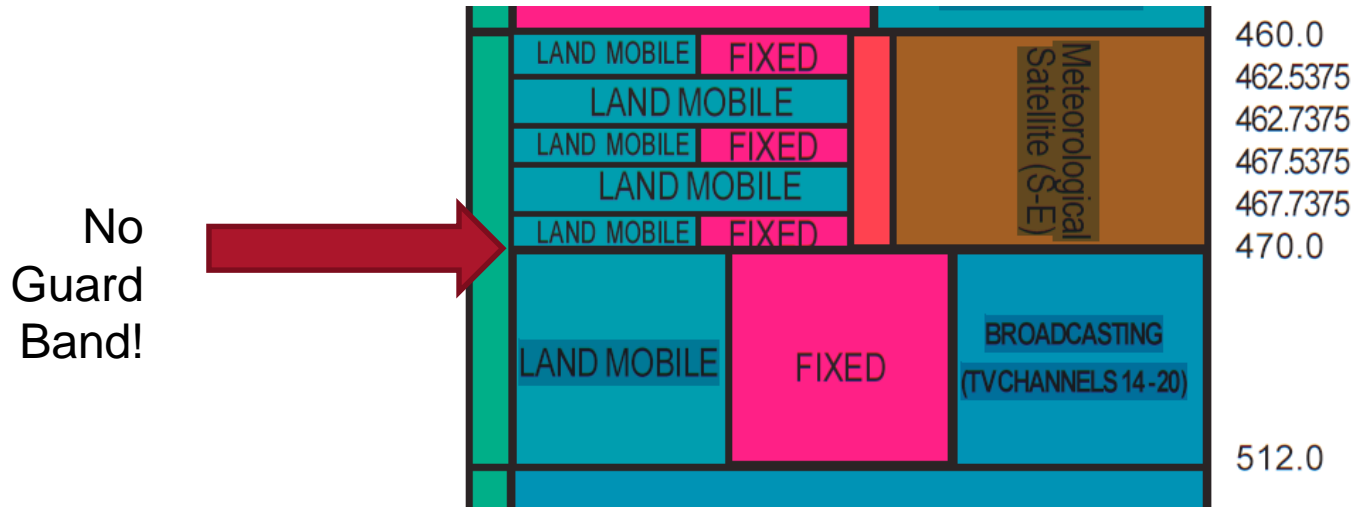

# Ch. 14 Mask Filters

- Unique to each Land Mobile RF situation

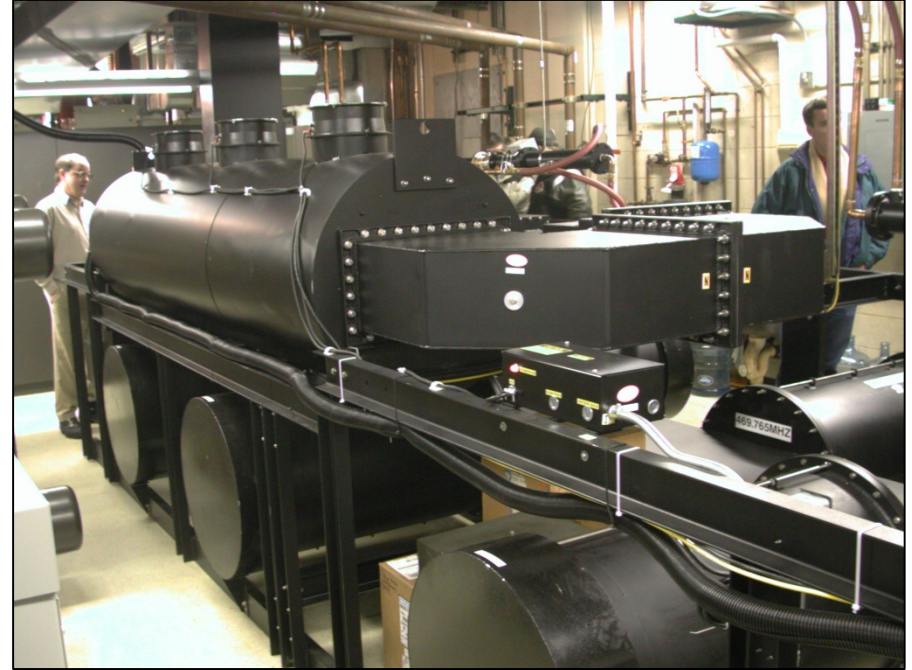

# Ch. 14 Mask Filters

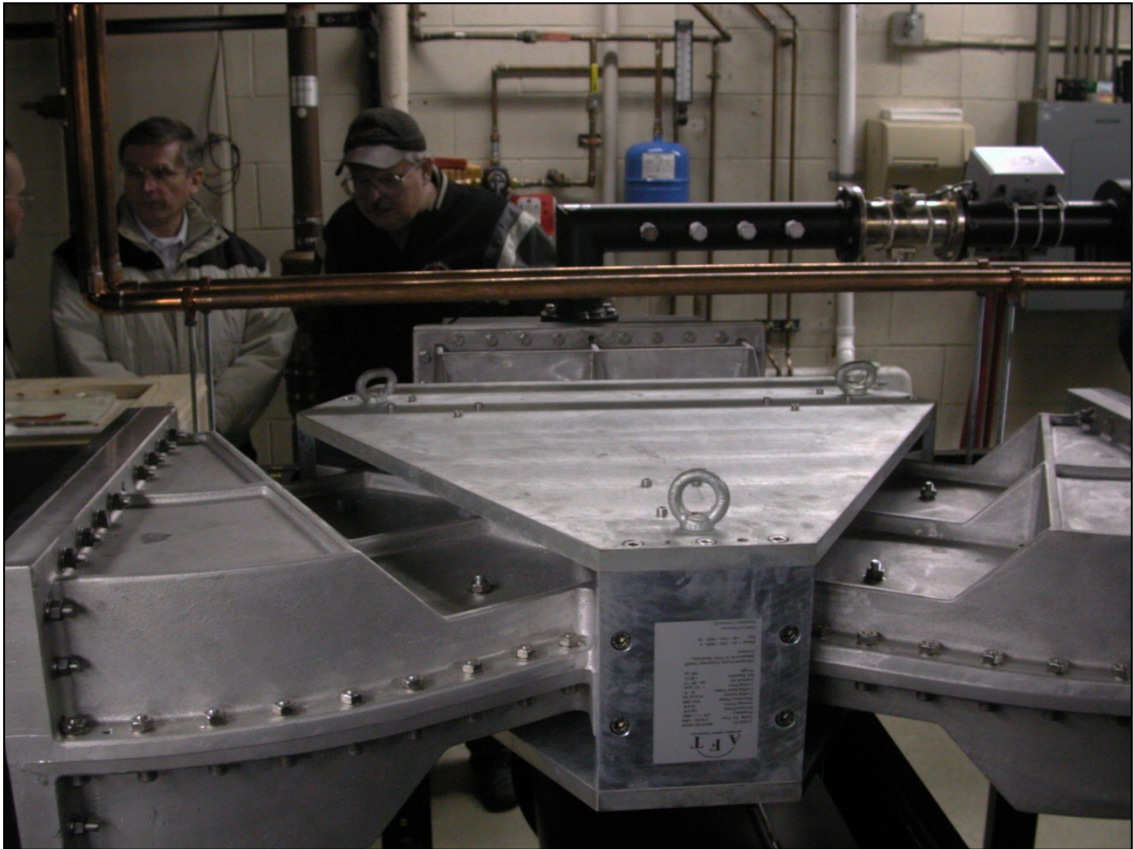



- We're on the clock!



# Construction Phases

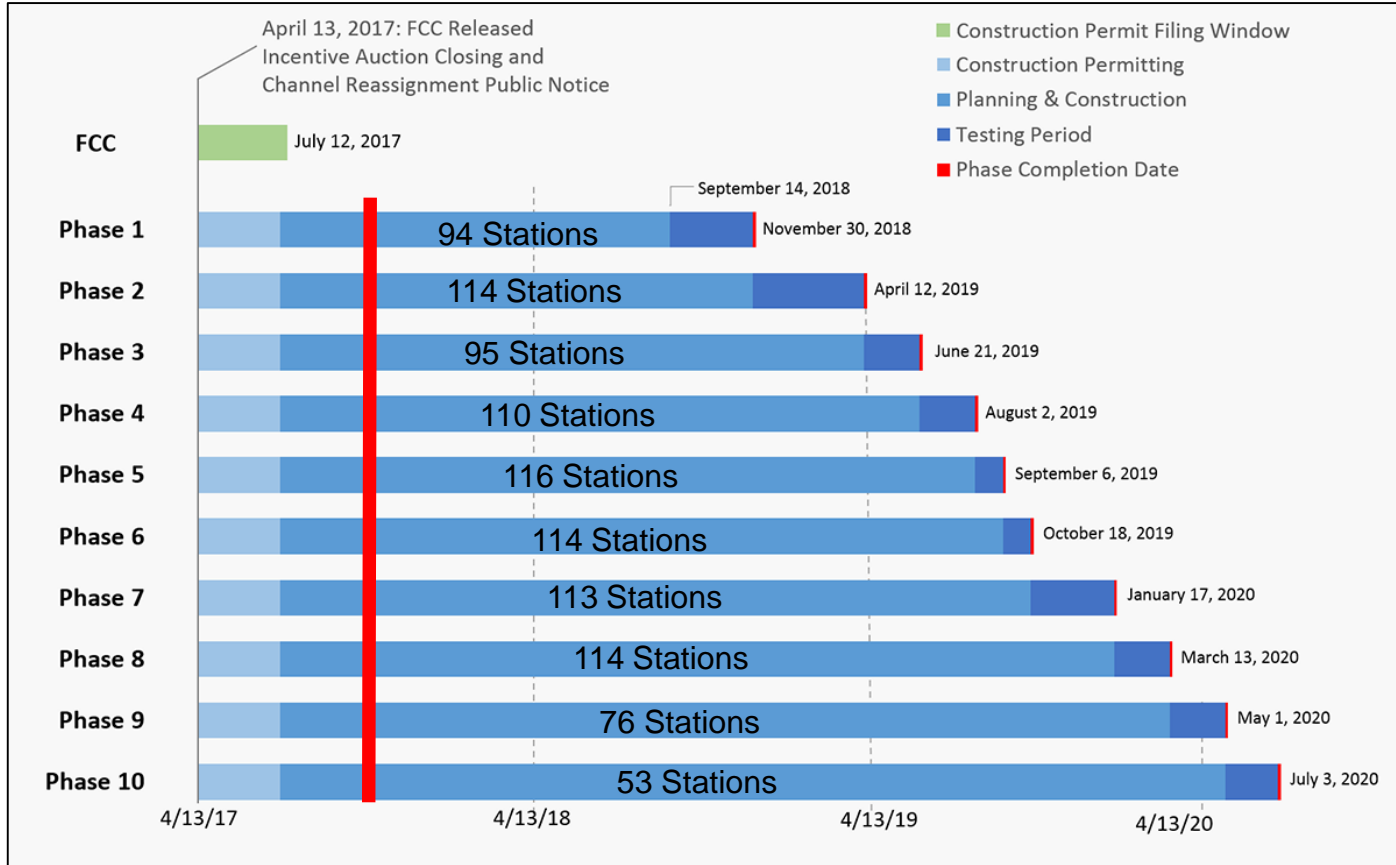

# Repack Regions

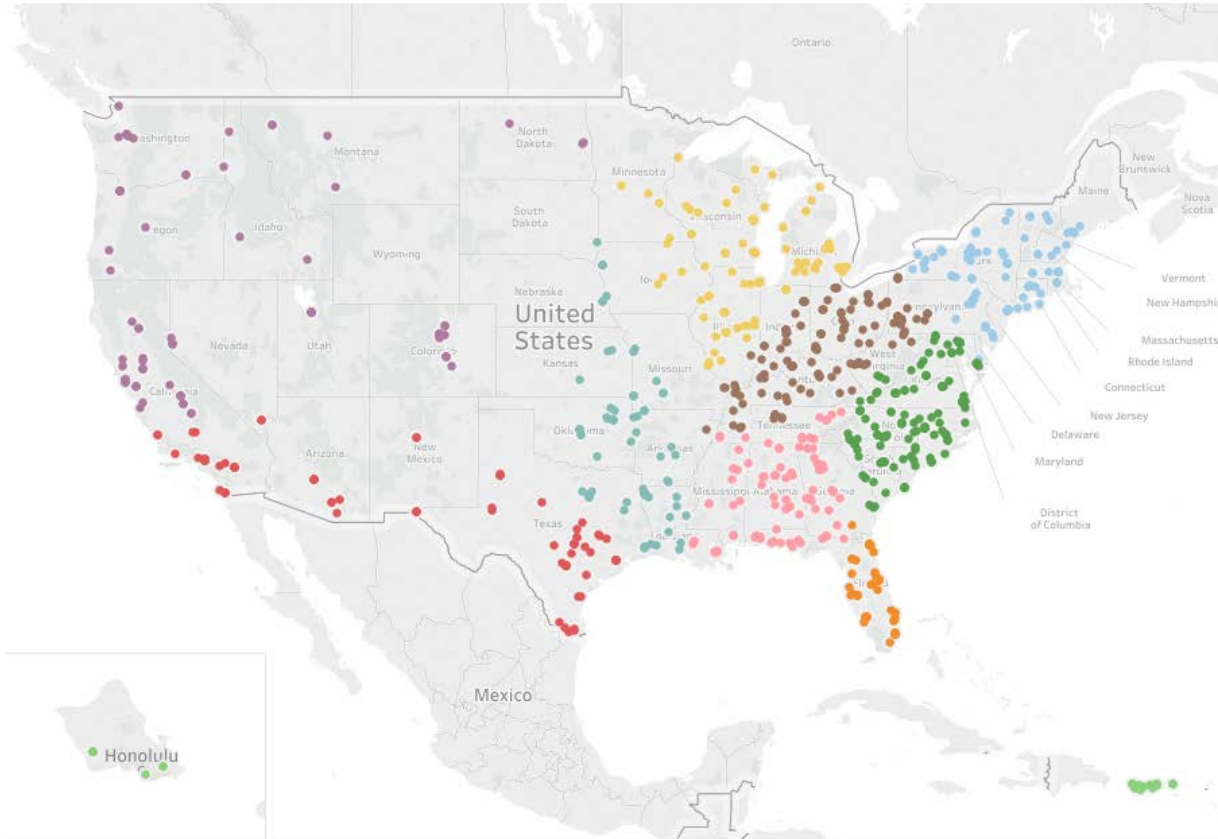

- Region
- Central Plains
  - Florida Peninsula
  - HI/PR/USVI
  - Mid-Atlantic
  - Midwest
  - Northeast
  - Northwest
  - Ohio River Valley
  - Southeast
  - Southwest



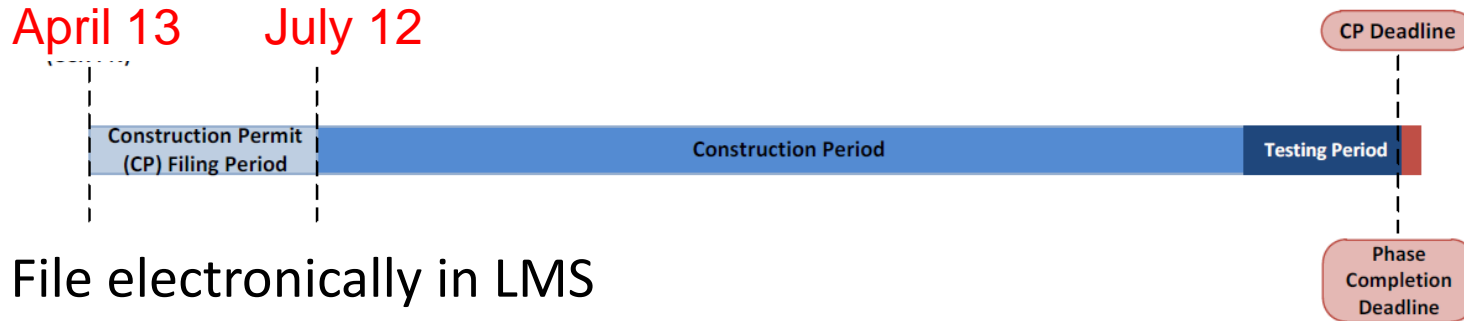

- File electronically in LMS
- FCC staff expected to process qualifying CP apps within 10 business days if:
  - Station not seeking expanded coverage beyond what was specified in the PN
  - Seeking authorization for no more than 5% smaller than what was specified in the PN.



# First Priority Window

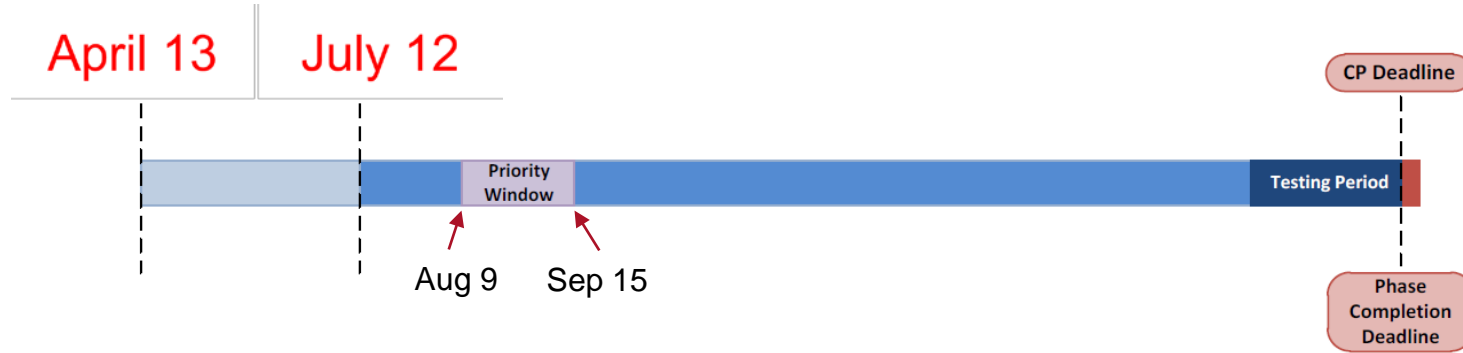

## ■ Limited to:

- Unable to construct – extraordinary technical or legal circumstances
  1. 25 stations were found by FCC to be unable to construct and given a July 12 waiver.
- Repacked stations predicted to experience a loss in excess of 1%
- Non-repacked stations predicted to experience a loss in excess of 1%
- Class A stations that were displaced and ineligible for repacking protection.



# First Priority Window Example

- Two stations on same tower under same ownership / operation.
- 1 VHF, 1 UHF
- Stacked antennas.
- Site has restrictions on additional antennas, so interim antenna is not possible.
- Assigned to two different phases.
  
- Solution: Apply to change to same phase so tower / antenna work is done simultaneously.



# Second Window – change requests

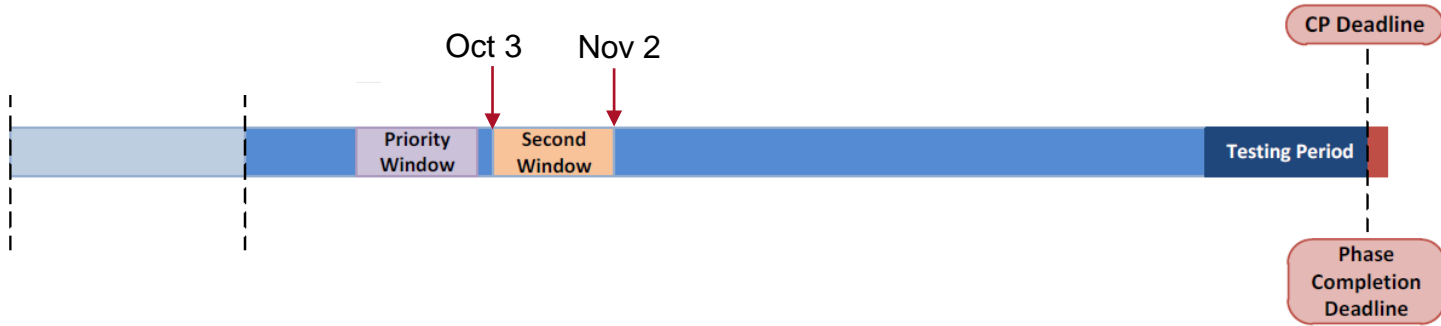

- Stations may use this window to request, among other things, an expanded facility, a different channel or channel swap with in-market station. (Amendment if CP still pending, modification if CP granted.)
- **Caution!! Alternate channels considered major change; subject to public notice and opportunity for petitions to deny and subject to filing fee.**
- Mutual Exclusivity that results from requests must be resolved in 90 days.
- Expenditures for upgrading facility that may be granted is non-reimbursable.



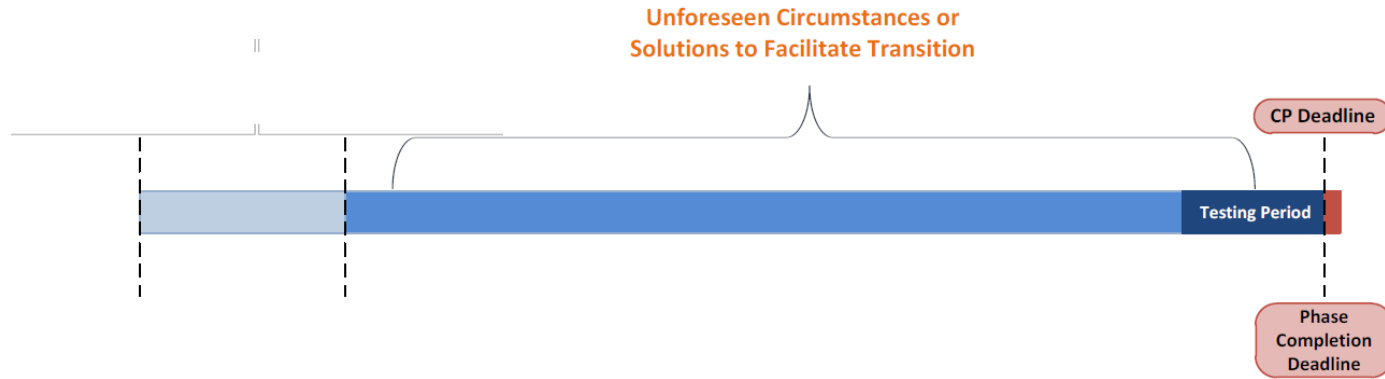

- If station is unable to construct new facility by the phase completion deadline... or
- If station is unable to cease operations on pre-auction channel by the phase completion deadline...
- ... Propose a creative solution to assist the transition process.





# Unable to construct on time

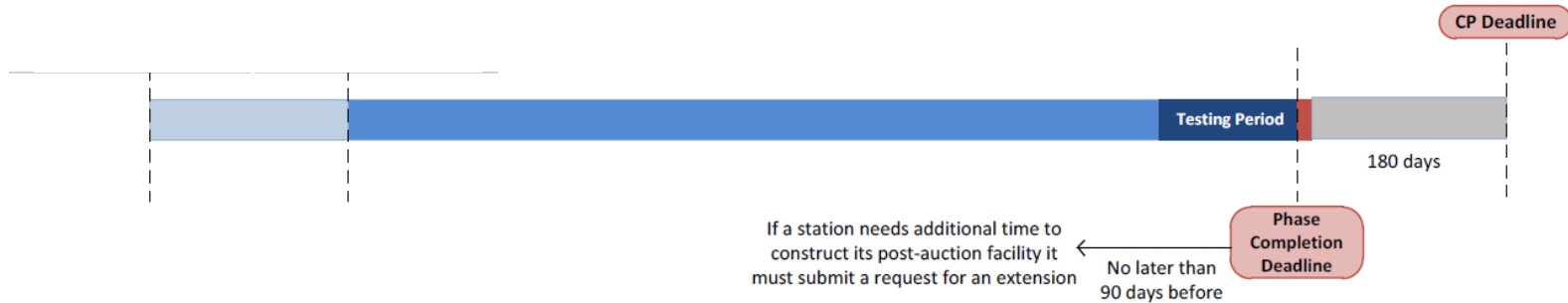

- Station may seek a single extension of up to 180 days; extension application must be filed at least 90 days before deadline.
  - Station may seek additional time beyond 180 days ONLY pursuant to “tolling”
    - Tolling: Acts of God, delays due to administrative or judicial review, ...
- Extending the CP deadline does not extend the phase completion date. Unless station is granted an STA otherwise, the date the station must cease operation on it’s pre-auction channel is on the phase completion date.



# Reimbursement



- Approx. 70% of applicants used the Widely catalog estimates to file 399's.
- Upgrades not covered by Widely
  - IOT vs. Solid State
    - IOT prices were submitted when station intended on Solid State to help ensure sufficient funding. These were caught by reviewers and needed to be amended.
  - H-Pol to E-Pol
    - FCC required reference / base cost to match assignment plus upgrade cost.
  - Professional services not covered by Widely or services > ~\$25k needed to be justified with a quote.
- Transmitter headroom
  - FCC agreed to moderate headroom, i.e. the next incremental transmitter power model / capability.



- Reviewers found that situations where actual quotes were provided were the easiest to review.
- Approximately 10% went through review w/o some sort of adjustment.
- Estimated 15% of applications needed sizeable adjustments.
- Valid quotes as part of 399 filing will ease approval of invoices.
- Auditors will be on the look out for a station that implements and invoices for something different than was planned.
  - Amend 399 before submitting invoices.
- Take the time to update estimates with actual quotes.



# Reimbursement Procedure



## ■ Initial Allocation

- Deposited to individual treasury accounts
- Commercial stations: up to 80% of estimated costs
- Noncommercial stations: up to 90% of estimated costs
- **Actual percentage will depend on total cost of repack vs. the \$1.75B repack fund**

## ■ Progress Reports

- Stations must report progress on implementing their channel transition plan
- First reports were due Oct. 10.

## ■ True-Up

- Broadcasters must submit documentation of actual expenses and estimated remaining expenses
- FCC will distribute additional funds or reclaim remaining funds, as appropriate



- Stations *indirectly impacted* not eligible for reimbursement
  - FM's on tower
  - Canadian neighbors (62 stations!)
- \$1.75 B broken down
  - \$1B authorized to borrow from treasury, \$750m from auction proceeds
  - Funds subject to sequester, 6 – 9%
  - Key words are “up to” (80% commercial, 90% non-comm)



# Reimbursement Example

- Reimbursement requests totaled \$2.1 B
- Actual may be less due to form 399 reviews and subsequent amendments, but not expected to go down significantly.
- \$1.75 B allocated, \$1 B available now.
- Assume 6% fund sequester
- Station estimate submitted is \$1,000,000
- Station's initial reimbursement would be:
  - $\frac{(1-6\%(1))}{2.1} \times \$1,000,000 \times 0.8 = \$358,095$
- Second reimbursement when forward auction proceeds fund the remaining \$750m (of the \$1.75 B)
- Will Congress take some action and cover all the costs?



- Introduced by NJ Rep. Frank Pallone in July
  - Create a \$1B additional fund to reimburse stations for repack costs.
  - Fund a \$90M viewer education effort
  - Fund would be authorized to reimburse FM stations for reasonable costs incurred due to repack.
  - Any left-over money available to LPTV's
  - Allow media bureau to grant permission to stay on air for situations out of a station's control.
  - No mention of indirectly impacted TV stations.
- Bipartisan support in congress.





# Executing the Repack



# Impact on Broadcast Technical Resources

- Large demand on consulting engineers time
- Structural analysis
- Transmitter installers
- Tower crews – new towers and antenna installation
- Just two weeks ago, we suffered 3 repack related tower fatalities of a qualified high tower crew.
  - Deadlines reassessed?
- Recent hurricane disasters may have crews busy that may impact early phase.
- May impact planned radio projects.
- May need to look for alternative resources.

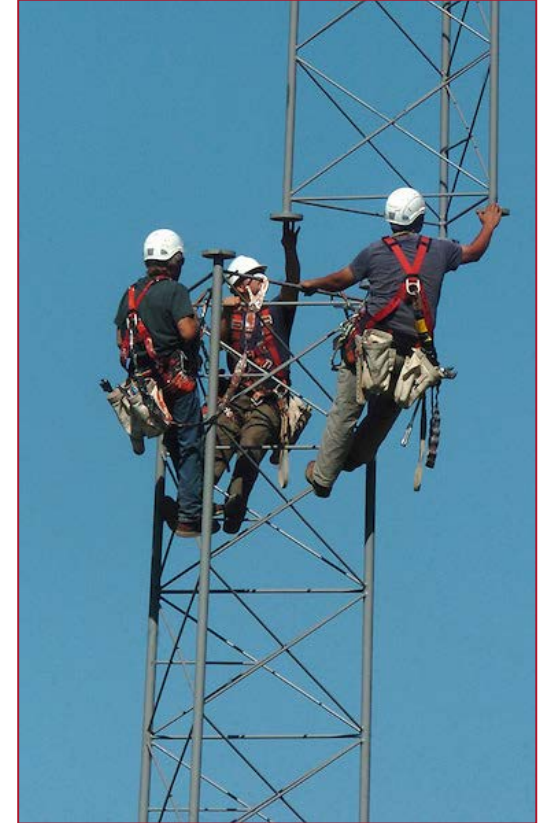

# Create a Plan

- New channel assignments are known
- Questions often asked:
  - Do I need V-Pol, and if so how much?
  - Will you need a rental/loaner transmitter?
  - What are the new electrical demands?
    - 480V vs. 240V
  - What is the size of the new transmitter?
  - Liquid or air-cooled transmitter?
  - What equipment can be re-used?
  - Can you provide full turn-key or project management?

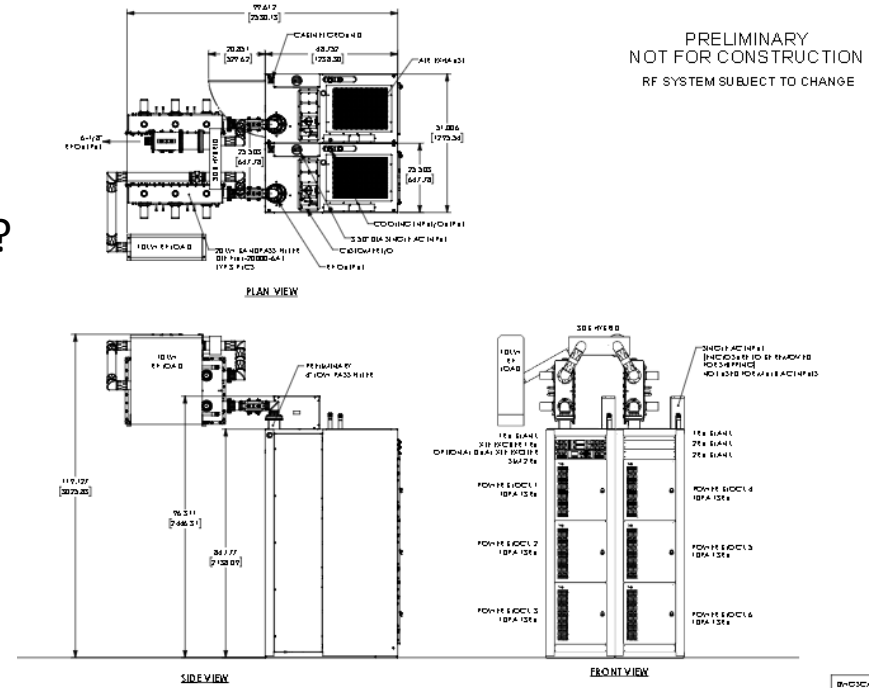

# Carefully Plan the Transition

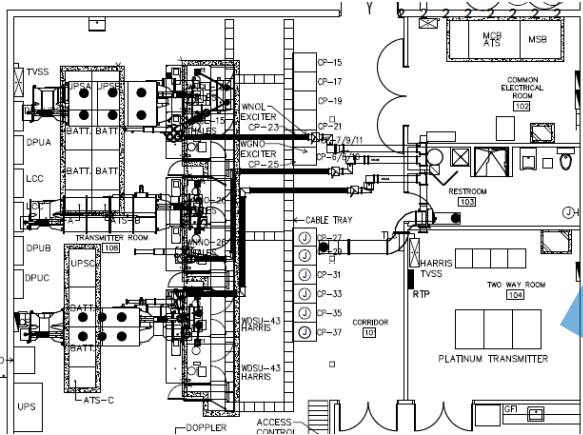

Today

- Current equipment placement

- Transition period
- Back-up transmitter, or temporary system

Transition

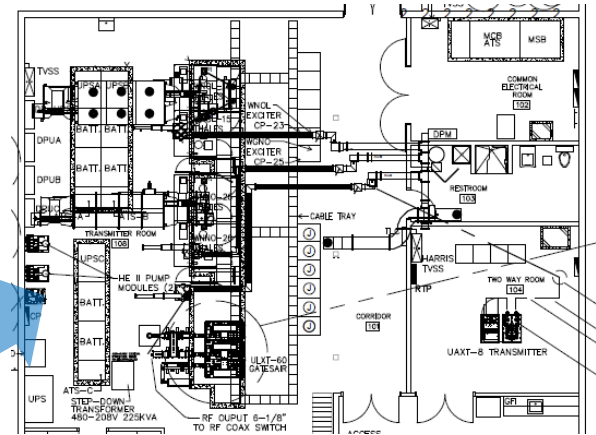
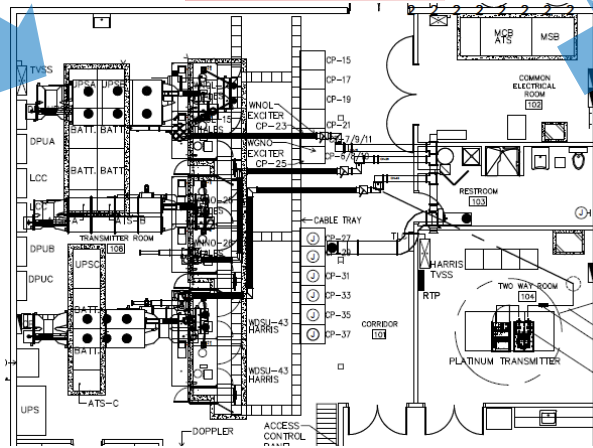

Tomorrow

- The finished project
- Follow-up with as-built, as sometimes plans change.



# RF System Layout Drawings

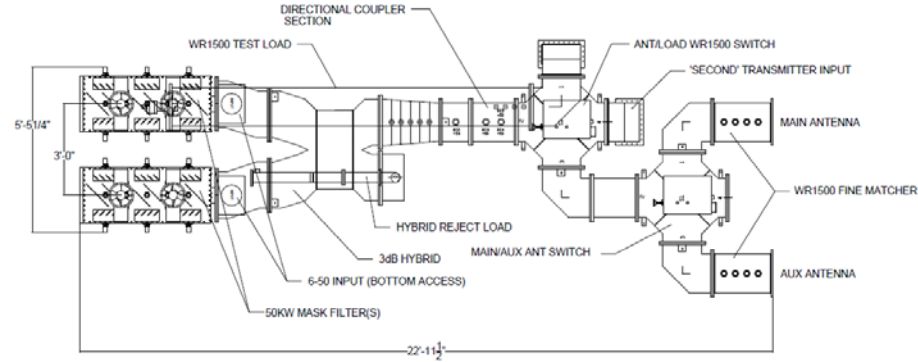
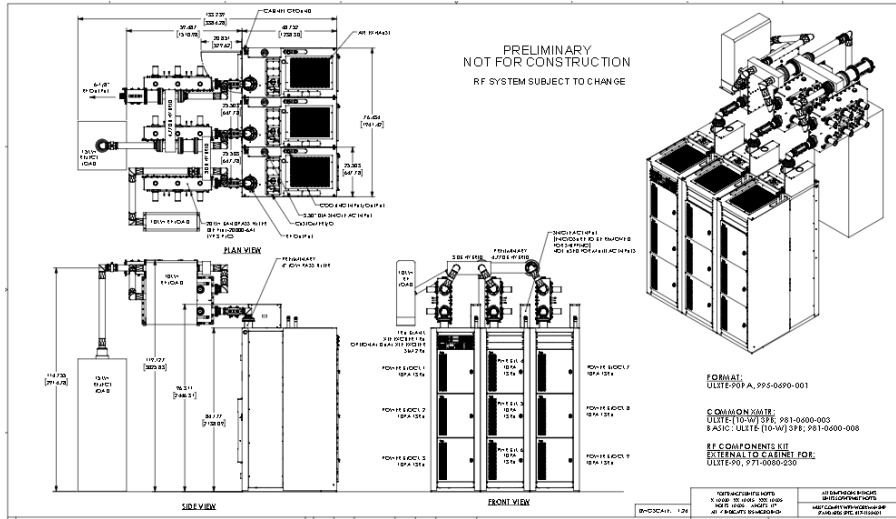

- System layout drawings will be invaluable when placing equipment in room

- RF system layouts specific to your equipment allows your team (or contracted installers) to better utilize the space available in your broadcast plant



# Electrical / AC Power Drawings

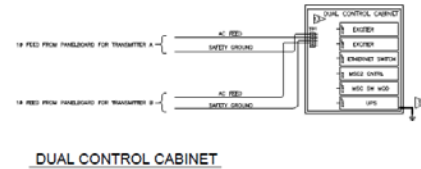
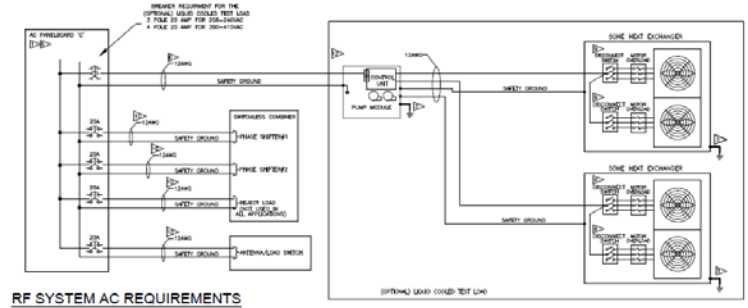
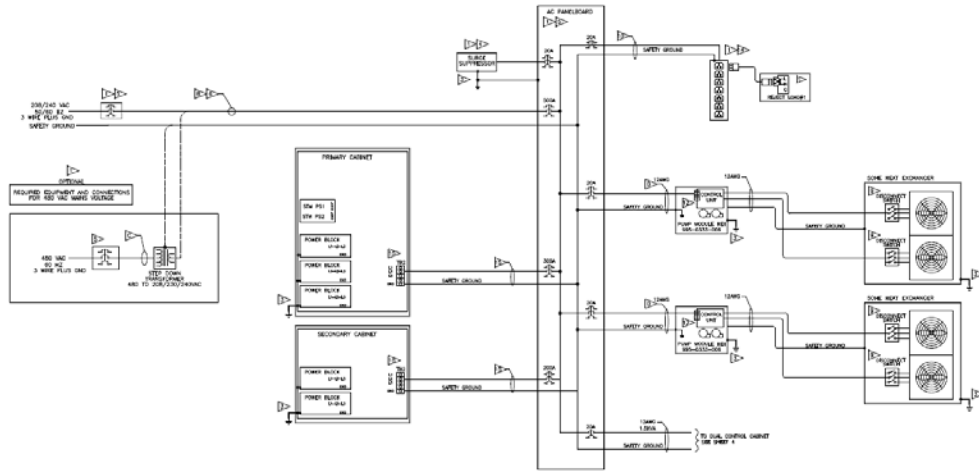

- Electrical drawings provide information to local trades on breaker & wire sizes and how the electrical connections are made



# Plumbing Drawings

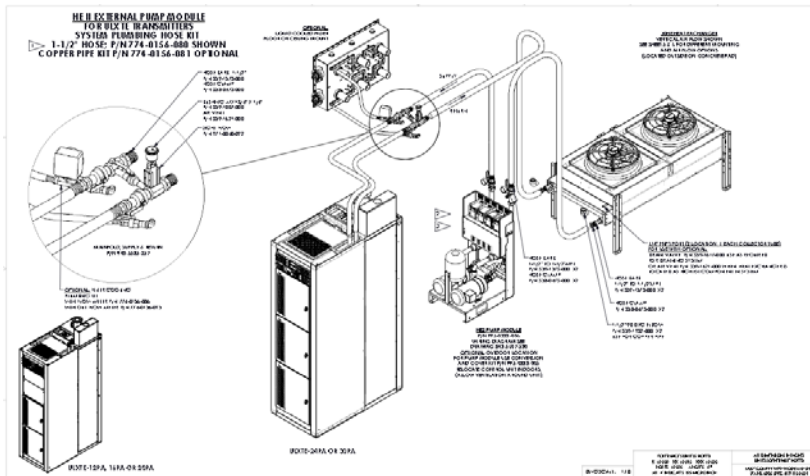

Single Cabinet Plumbing

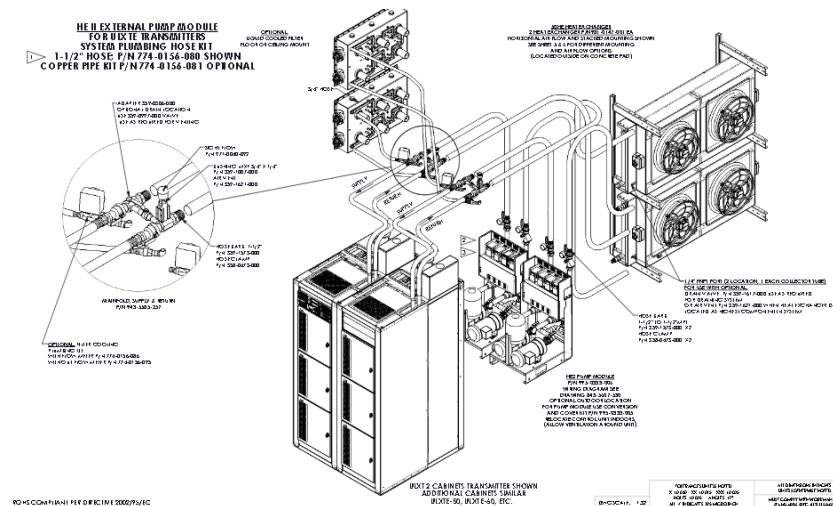

Multiple Cabinet Plumbing

- Depending on your location and applicable local/city/state codes you may have your transmitter supplier install the plumbing, or use a local plumber.



- Initial equipment and services requirements will be driven by phase assignments.
  - What phase are you in?
  - Do you have local coordination already planned?
- Your station may need a temporary antenna, transmission line and replacement or standby transmitter to maintain service while rebuilding the primary transmission system





# Rental & Moveable Transmitter Systems

*“Can I rent a transmitter to use while my old transmitter and RF system is being removed?”*

- Some manufacturers may be able to provide a rental transmitter
- Typical systems 2kW up to 10kW
- Air-cooled is better for short term operation but liquid-cooled is possible
- “Tx in a Trailer” solution can be moved site to site during repack

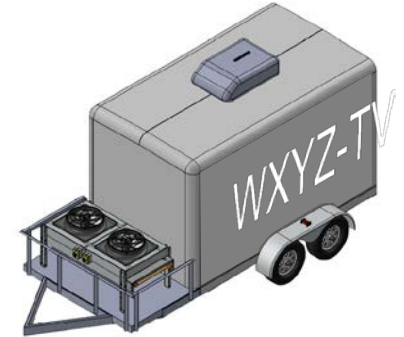
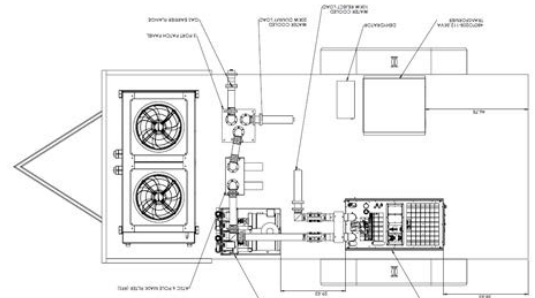

Trailer - Transmitter



# On Channel Transition Scenario



1. Install temporary antenna and transmission line for existing channel or move to standby antenna if available
2. Transition current channel operations to temporary or standby antenna (Likely at reduced power and coverage)
3. Remove former main channel antenna and possibly transmission line
4. Install new main antenna and possibly transmission line
5. Install new transmitter and RF system
6. Test phase (30 day test window)
7. Commence operation at full power and coverage on new channel (coordinated Phase cut-over day)
8. Remove or retune old transmitter, if possible, as a backup.



# New Channel Transition Scenario

What if: Unable to complete construction by end of phase (e.g. tower mod's) or other obstacles. May need to get creative.

1. Install temporary antenna and transmission line for new channel
2. Install new transmitter, retune existing standby transmitter to new channel or obtain rental transmitter.
3. Install new RF mask filter and RF system
4. Transition operations to new channel (Likely at reduced power and coverage)
5. Remove former main channel antenna and possibly transmission line
6. Install new main channel antenna and possibly transmission line
7. Commence operation at full power and coverage on new channel
8. Remove old transmitter if unable to retune as backup TX



# Shared Antenna Transition Scenario



1. Install temporary antenna and transmission line for current channel or rely on a backup antenna if available
2. Transition operations to temporary antenna or backup antenna (Likely at reduced power and coverage)
3. Remove former main channel antenna(s) and transmission line(s)
4. Install new main multichannel antenna and transmission line
5. Install RF combining system for multiple stations
6. Install new transmitter, mask filter and RF system for each station
7. Switch all stations over to new channels
8. Remove old transmitter(s) or retune if possible as standby TX's



- Two major considerations during repack will impact your future transition to ATSC 3.0
  - Purchasing the right antenna
  - Purchasing the right transmitter



# ATSC 3.0 and Antenna Replacement

- ATSC's Physical Layer was designed to reach mobile, portable, handheld and receivers with indoor antennas.
- Signal density, lower C/N and improved error correction
- All stations should consider adding V Pol if replacing an antenna during repack. Stations will have to add additional money to the purchase.
- Substantial long term savings gained by not having to replace an antenna later.



- Considerations when selecting a replacement transmitter during repack:
  - Are the exciters upgradable to ATSC 3.0?
  - If adding V-Pol, will the transmitter have sufficient power capability?
    - Example: To maintain licensed H-Pol power, adding 30% V-Pol requires a **43%** TPO increase.
    - $\frac{1}{0.7} = 1.43$  Similarly 20% V-Pol  $\Rightarrow \frac{1}{0.8} = 1.25$  Tx sizing.
    - Stations will have to add capital for the extra transmitter sizing.
  - Long term savings from not having to replace or add power to the transmitter when transitioning to ATSC 3.0.



# Key Takeaways

- Stations not required to change channels may be impacted
- Staying **ON AIR** during repack will **most likely require some additional equipment**
- **Detailed** preparation for repack should begin **ASAP *if not done already!***
- In most markets and regions, **cutover** will need to be **coordinated and carefully managed**





# Further ATSC 3.0 insight is available at:

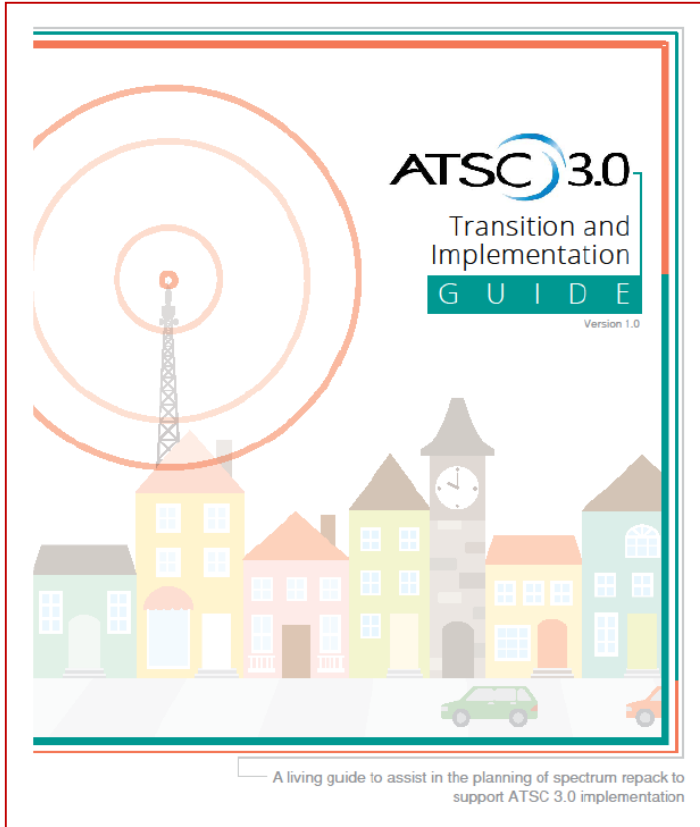

<http://info.gatesair.com/atsc-3.0-guide-download>

